



GREASE GUARD[®]

Rooftop Defense Systems[®]

Assembly and Installation Instructions



Table of Contents

Parts List (G2 [®] Exploded View)	1
G2 [®] Applications	2
Tools Required	3
Installation Basics & Tips	3
General Guidelines and Safety Information	3
G2 [®] Frame Features	4
G2[®] Frame Assembly	4
G2 [®] Filter Features	6
G2 [®] Filter Installation Types	7
G2[®] Filter Curb Cut-Out Measuring	7-9
Cutting G2[®] Filters	9
Installing Cut G2[®] Filters into Frame	10
Filter Unit Layouts	11
Hold Down Pole Install	12
Flashing Installation	13

Parts List

Note:

Quantities may vary for larger and custom units.

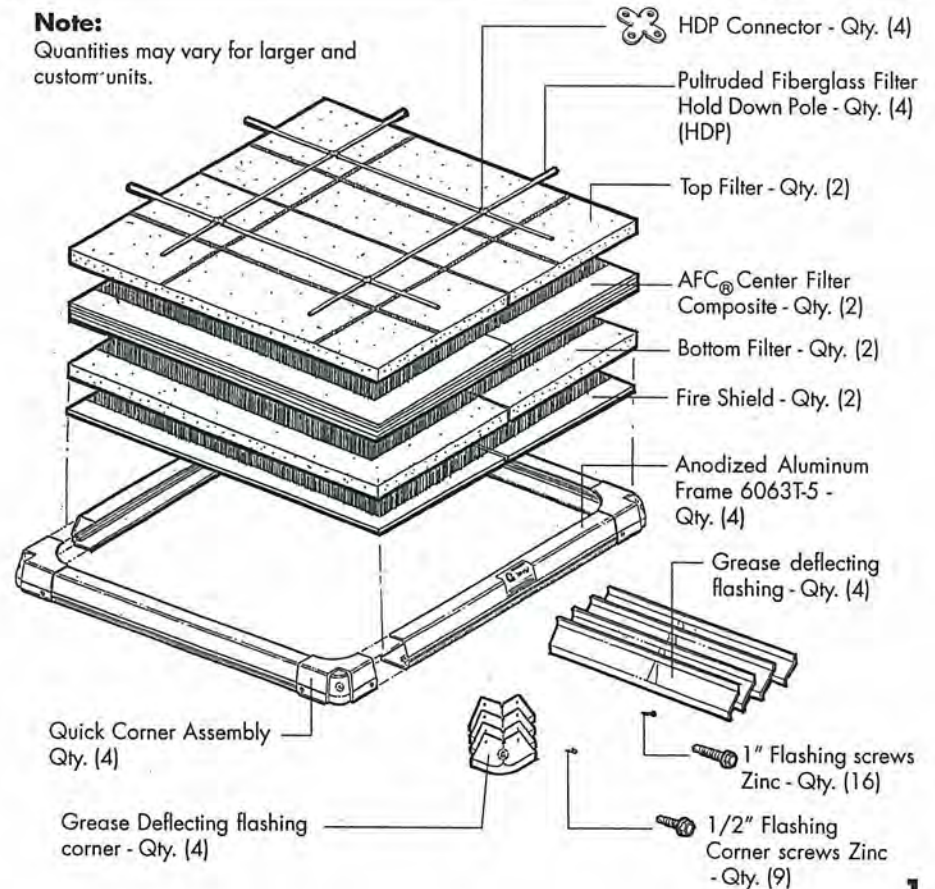

G2[®] Grease Guard Applications

Food Service
Standard Upblast Kitchen Exhaust Fans

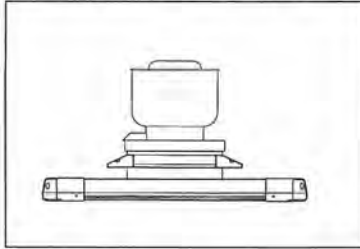

Food Service
Box Style Kitchen Exhaust Fans

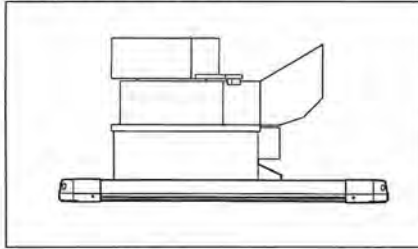

Food Processing \ Industrial
Vented Vapor and Heat Discharge Systems

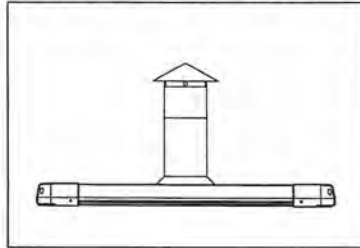

Food Service \ Industrial
Utiliset Exhaust Fans

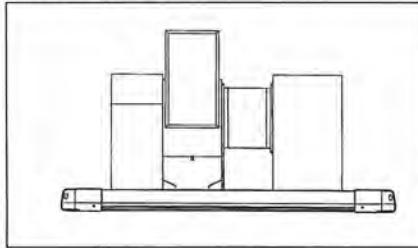

Industrial
Side Mounted Pipes

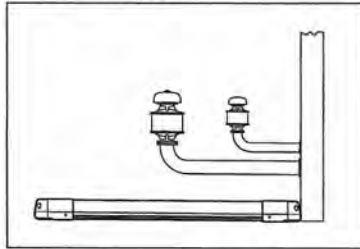

Food Processing
Oil/Grease Vapor Extracting Systems

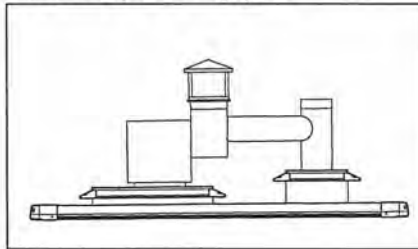

Manufacturing
Direct Discharge Piping

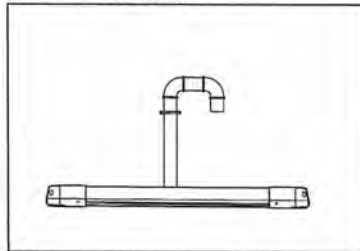

Motor/Generator
HVAC Motor/Generator Area Oil Containment

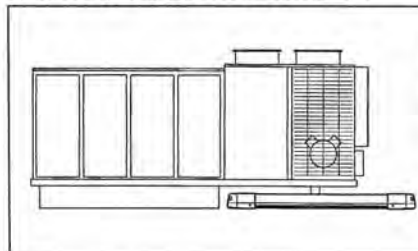

Tools Required

The following tools are required for the installation of the G2 Grease Guard:

- 5/16" Hex key (provided with unit)
- 5/16" Hex head drive socket
- Drill (recommended for 5/16" hex head screws)
- Industrial type Scissors - (sharp)
- Tape measure
- Permanent marker
- Straight edge

Installation Basics and Tips

Before you begin to install the G2 Grease Guard, there are some basic installation requirements that need to be followed.

These instructions contain two icons which aid in the proper installation of the G2 Grease Guard.



This icon will give installation tips which ensure the proper installation of the G2 Grease Guard.



The warning icon will point out areas that require extra attention.

General Guidelines and Safety Information

Do not attempt to install G2 Grease Guard under inclement weather, high winds, electrical storms or ice conditions, that will make installation dangerous. Stay clear of all power lines, antennas and phone lines during the installation.

! Warning!

Do not under any circumstances use a utility knife to cut the filters!



Utility knives will cut through to the roof surface causing serious damage to the roof. You will be responsible for any roof damage caused to the roof by the use of utility knives!

Introduction to Frame Assembly - G2 Frame Features

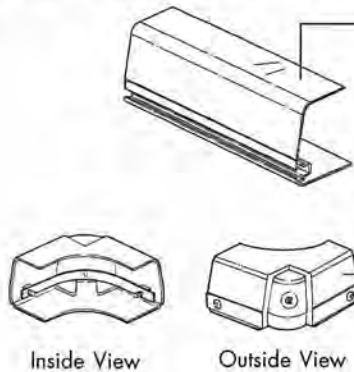

Anodized Aluminum Frame 6063T-5
Complies with ASTM B-221
Frame holds filter media in place

Molded Quick Corner

Made from copolymer which resists corrosion, UV rays and extreme temperatures. Provides for fast and efficient joining of the anodized aluminum frame.

Quick Corner Hardware Assembly:

Inside View: (2) 5/16" square nut - zinc
(1) Corner Strap Guide - zinc
Outside View: (2) 5/16"-18 button socket

5/16" Hex Wrench

Used for tightening molded Quick Corner to the anodized aluminum frame.



Step 1

Quick Corner Hardware Assembly

Loosen each Quick Corner Hardware Assembly 3 (counter clockwise) revolutions using 5/16" hex wrench. (If screw backs out - press back into Quick Corner.) Repeat this procedure on hardware assemblies for all (4) Quick Corners.

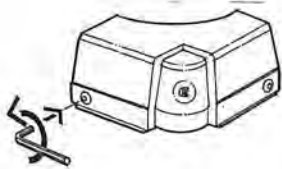

Loosening the Quick Corner Hardware Assembly is necessary for proper fit with Frame extrusions.

Step 2

Attaching Quick Corner to Frame

Align Frame track with the square nut and corner strap guide inside the Quick Corner. Insert Frame until it stops inside Quick Corner. Once Frame is inserted use the 5/16" Hex Wrench to tighten and secure Frame to Quick Corner.

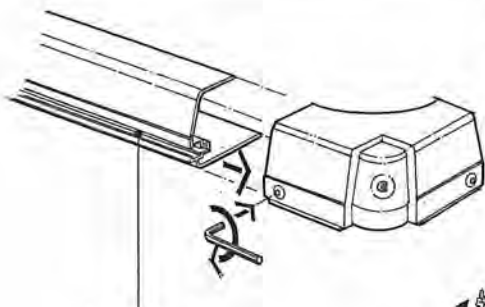

Frame Track



Refer to **Step 3** for proper sequential order of Frame and Quick Corner assembling.

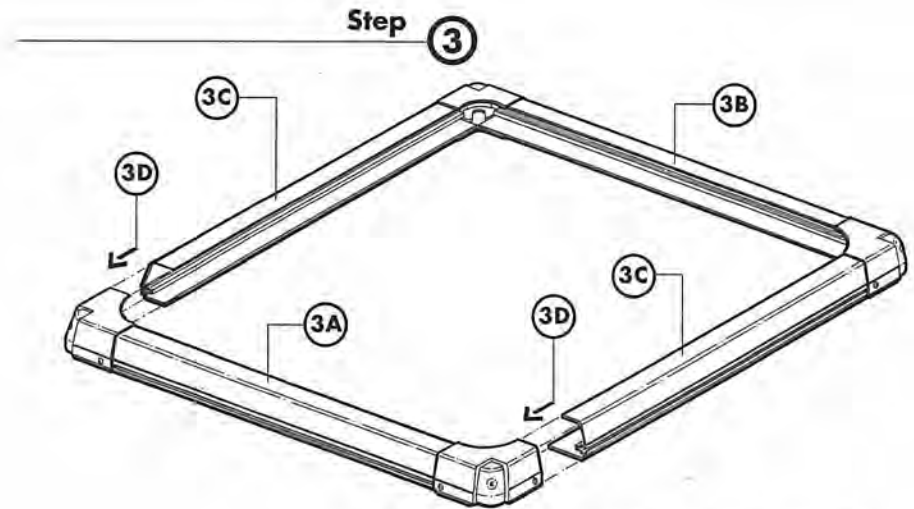

Always construct the frame around the curb or fan.

Step

3A

Referring to the instructions from **Step 2**, attach (1) Quick Corner to each end of **Frame 3A**.

Step

3B

Referring to the instructions from **Step 2**, attach (1) Quick Corner to each end of **Frame 3B**.

Step

3C

Attach both **Frame 3C's** into the Quick Corners joined to **Frame 3B** to form a "C" shape (as shown above).



It is necessary for the (3) Frames in Step 3C to be joined together in this "C" shape. It will allow for a fast and efficient joining for Frame 3A assembly without bending the frame.

Step

3D

Complete assembly of the frame by inserting the ends of the "C" shape (refer to Step 3C) into the Quick Corners attached to Frame 3A. Once in place, be sure to tighten and secure all Quick Corners to the Frames using the 5/16" hex wrench.



Frame extrusions are numbered in diagram for **Step 3** of the instructions only! The actual frame extrusions are not physically numbered.

Introduction to Filter Installation – G2[®] Filter Features

The **G2[®] Advanced Filter Composite[®] or AFC[®]**, has been designed to provide greater absorption capacity, more efficient separation of grease and water and a higher resistance to UV degradation.

The following is a description of the G2[®] filter components in their proper arrangement.

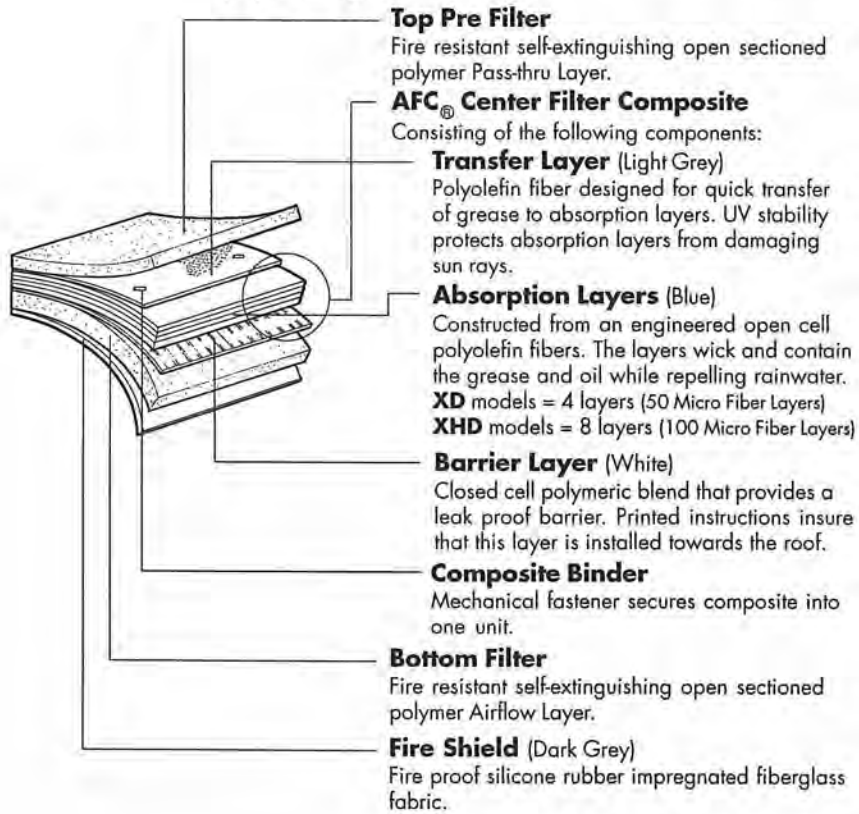

Override Barrier Layer

The Barrier layer is 3" oversized on one side of each composite. Be sure to install the AFC's with the oversized Barrier layer's overlapping at the seam as shown here. This insures a leak proof seam.

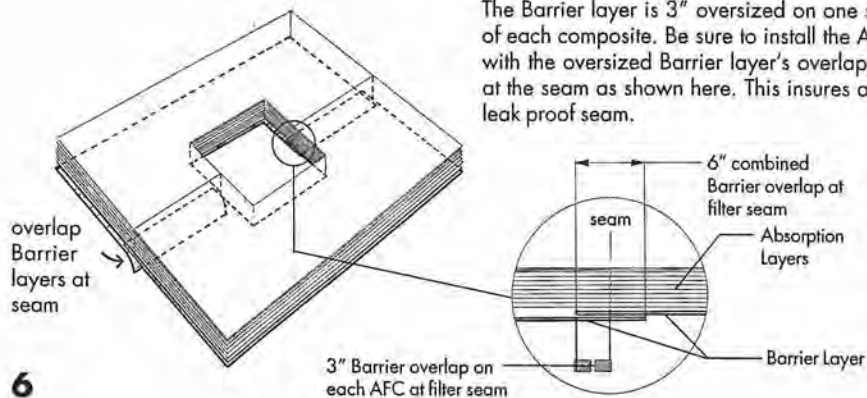

G2[®] Filter Installation Types :

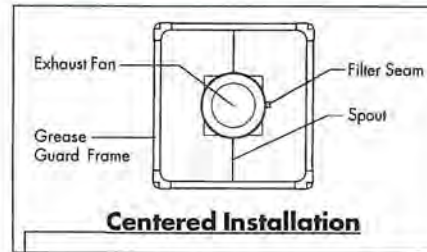

Go to **Step ①** of G2[®] Filter Measuring Section

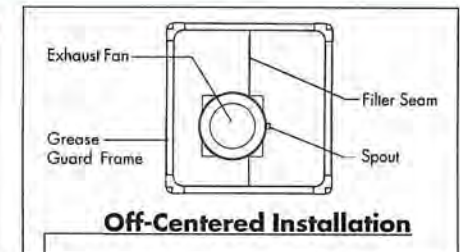

Go to **Step ②** of G2[®] Filter Measuring Section

G2[®] Filter Curb Cut-Out Measuring

Step ①

Centered Installation

- Measure two adjoining sides of the curb.
- Record the dimensions in the space provided below.

Dimension A	Dimension B
<input type="text"/>	<input type="text"/>

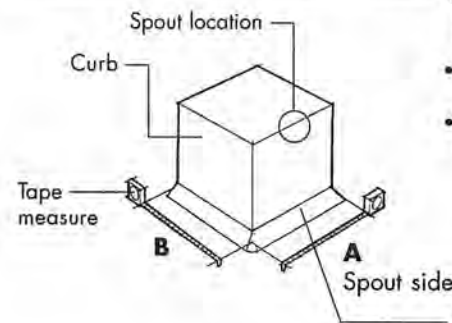

Cant - When a Cant is present refer to **Step 3** for measuring filters to fit.



Always place filter seam along side B, away from Spout Side A.

Step 1A



Draw Pattern for Curb Cut-Out onto Filters in the proper order which they are placed into the frame; **Fire Shield, Bottom filter, AFC, and Top Pre Filter.**



Be sure to measure and cut the AFC layer with the 3" oversized Barrier positioned at the seam.

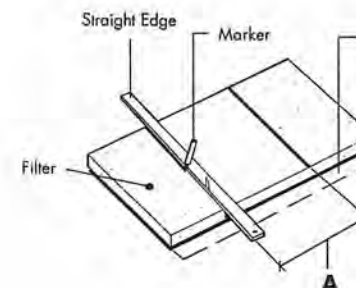

Width = Dimension A centered onto filter.

Draw the width (Dimension A) pattern onto one half of the filter layer as shown in the illustration.

Use a marker and a straight edge to draw the curb cutout pattern onto filters.



A piece of flashing makes a good straight edge.

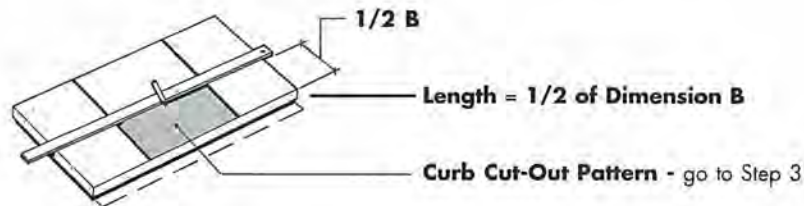

Length = 1/2 of Dimension B

Curb Cut-Out Pattern - go to Step 3

Step 2

Off-Centered Installation

- Measure the distance from the outside edge of the frame to the curb on all sides of the unit as shown in the illustration.
- Record the dimensions in the space provided below.

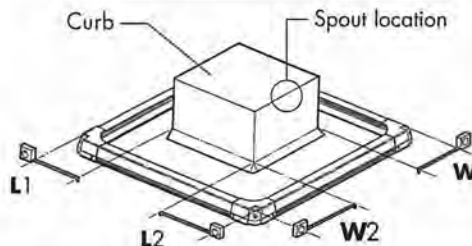

Dimension L1

Dimension L2

Dimension W1

Dimension W2

! Always place filter seam along side of curb opposite the spout side.

Step 2A

Draw Pattern for Curb Cut-Out onto Filters in the proper order which they are placed into the frame; **Fire Shield, Bottom Filter, AFC, and Top Pre Filter.**

Width = Dimension W1 & W2

Draw the width (Dimension's W1 & W2) pattern onto both halves of the filter layer as shown in the illustration.

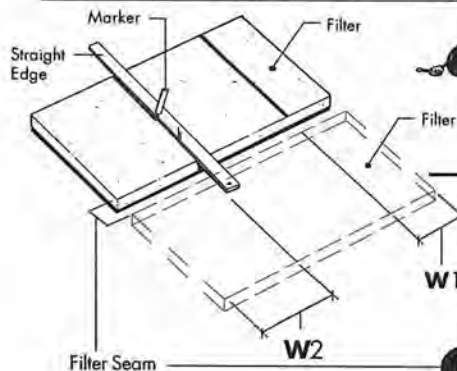

! Be sure to measure and cut the AFC layer with the 3" oversize Barrier positioned at the seam.

Use a marker and a straight edge to draw the curb cutout pattern onto filters.

Length = Dimension L1 & L2

Draw the length (Dimension's L1 & L2) pattern onto both halves of the filter layer as shown in the illustration.

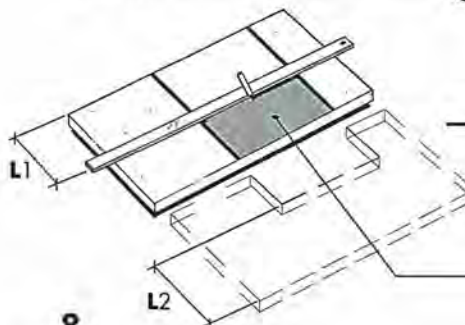

Curb Cut-Out Pattern - go to Step 3

Step 3

Measuring a filter curb cut-out with a cant

Typically, the cant of the curb falls into the area where the filters are to be installed. This will cause the curb cut-out patterns to be different for Bottom Filter layer, AFC layer, and Top Pre Filter layer.

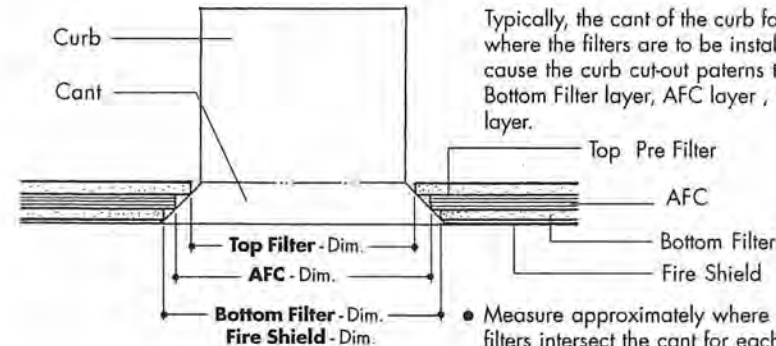

- Measure approximately where the edge of the filters intersect the cant for each filter layer as shown in the illustration.

Repeat Step 1 or Step 2 for each filter layer to ensure a tight fit up against curb cant.

Cutting G2 Filters

Step 1

Cut-out pattern

Using sharp industrial scissors, cut-out pattern drawn in Step 1 or Step 2.

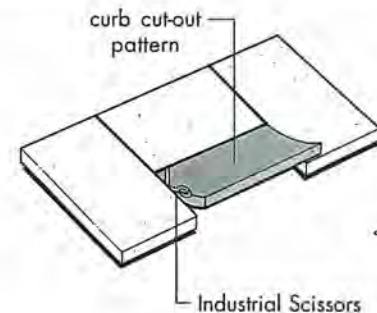

For best results when cutting the AFC, cut thru 2 absorption (blue) filters at a time.

Step 2

Check cut filter for fit

Lay cut filter into frame to check fit with the curb. A good fit would be tight up against the curb with no gaps between the curb and the cut filter.

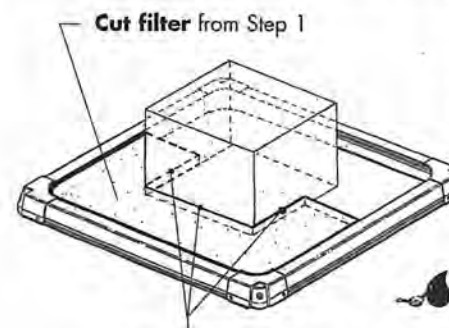

Check for: Tight fit with no gaps against curb.

For centered installation with no curb cant, use this filter as a template to cut the rest of the filters.

Installing Cut G2® Filters into the Frame

Install filters into frame

Tuck filters under top lip of frame so that they lie flat. There should be no wrinkles or edges sticking up when the filters are properly positioned.

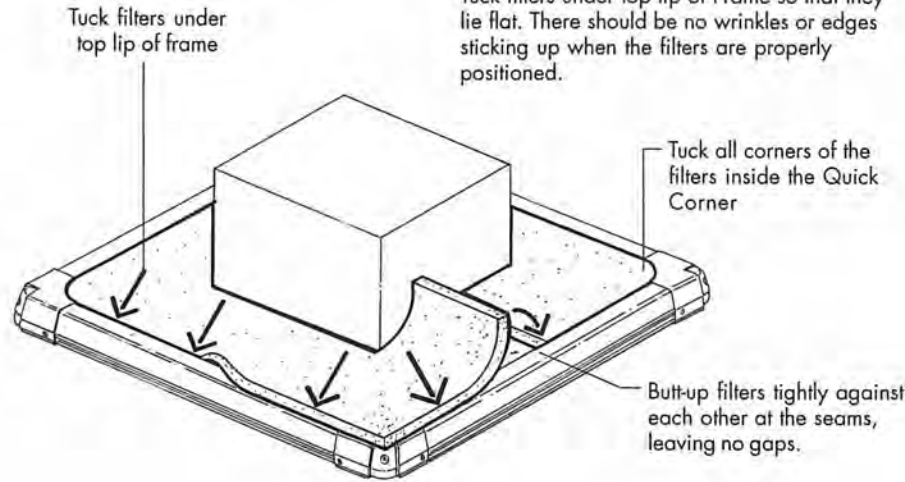

When the filter seam is located at a grease spill area, be sure to take any scrap Absorption filters and place them on top of the seam for added protection. Always try however, to place seam away from a grease spill area.

! Be sure to install the AFC's with the oversized Barrier layer's overlapping at the seam as shown here. This insures a leak proof seam.

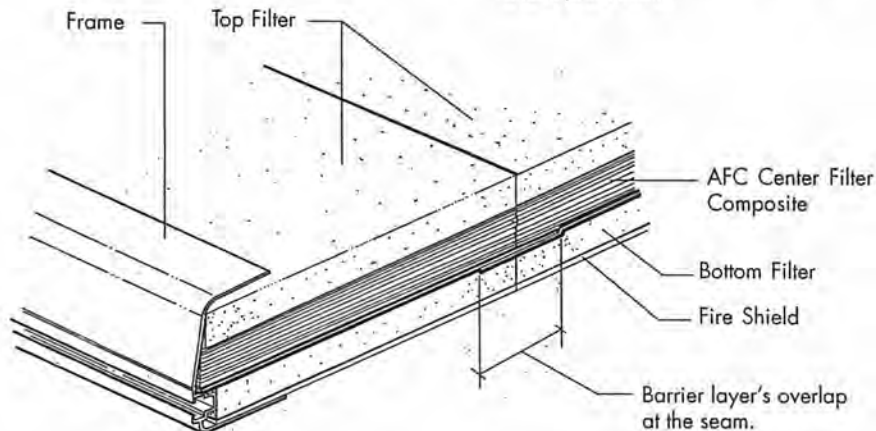

Modular Filter Layouts: Plan View

All modular filter layouts below are shown as solid filter units without a curb cut-out. Refer to the G2 Filter Curb Cut-Out instructions starting on page 7 for adding a curb cut-out to your application.

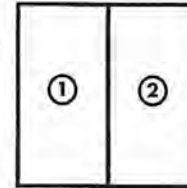

Unit	Filter Size
G2-48	24x48
G2-60	30x60
G2-72	36x72

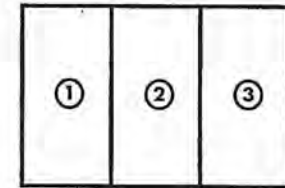

Unit	Filter Size
G2-60x90	30x60
G2-72x108	36x72

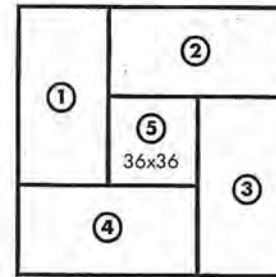

Unit	Filter Size
G2-90	30x60, 36x36
G2-108	36x72, 36x36

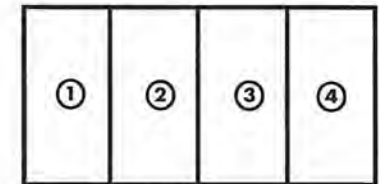

Unit	Filter Size
G2-60x120	30x60
G2-72x144	36x72

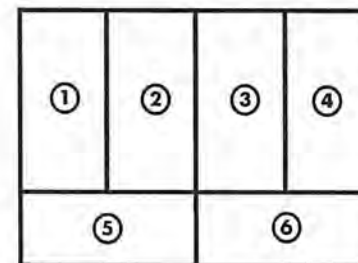

Unit	Filter Size
G2-90x120	30x60
G2-108x144	36x72

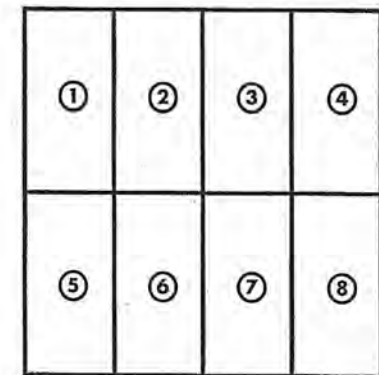

Unit	Filter Size
G2-120	30x60
G2-144	36x72

Hold Down Pole Installation

Step 1

Hold Down Pole Grid Configuration
With four fiberglass Hold Down Poles (HDP), construct a grid as shown with the four HDP.

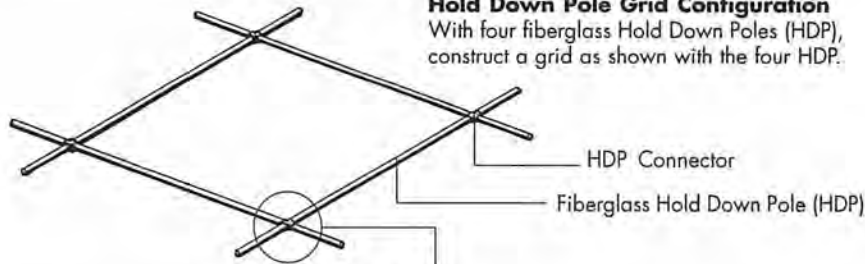

Step 1A

HDP Connector Installation
HDP Connectors keep HDP in place and allow for easy HDP removal during filter replacement.

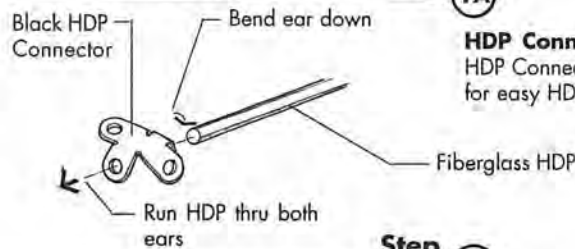

Step 1B

Insert second HDP thru ears (second HDP slides under first HDP)

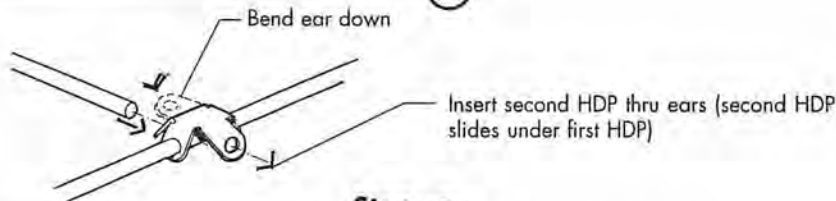

Step 2

Installing HDP into Frame
Place each end under the top lip of the frame. Bend the poles (as shown) in order to get them into place under the top lip of the G2 frame.

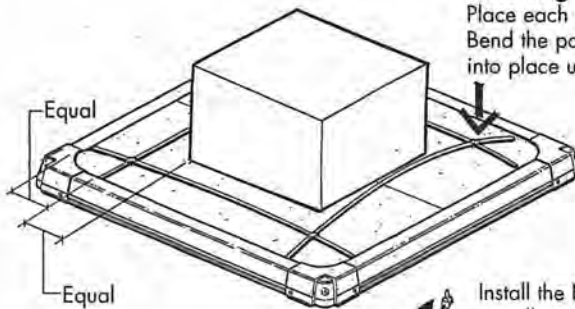

- Install the Hold Down Poles so that they are equally spaced (as shown) between the side of the curb and the G2 frame.
- When inserting HDP's into the frame, prevent the end of the HDP from tearing into the Top filter.

Flashing Installation

Step 1

Mounting Grease Deflecting Flashing
The Grease Deflective Flashing must be installed with the G2 Grease Guard to insure proper draining of grease into the filters.

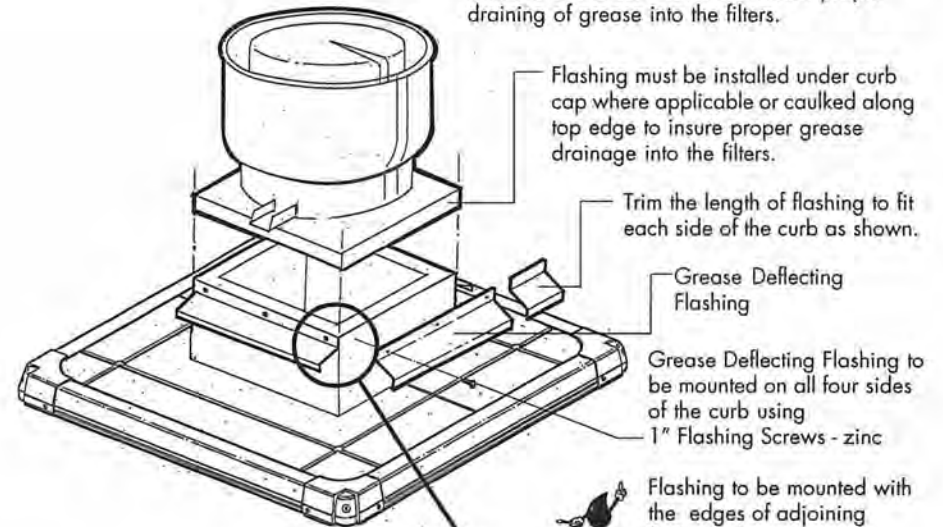

Step 2

Installing Flashing Corner
The Flashing Corner must be installed with the G2 Grease Guard to insure proper draining of grease into the filters and to cover-up all sharp edges on trimmed Grease Deflecting Flashing.

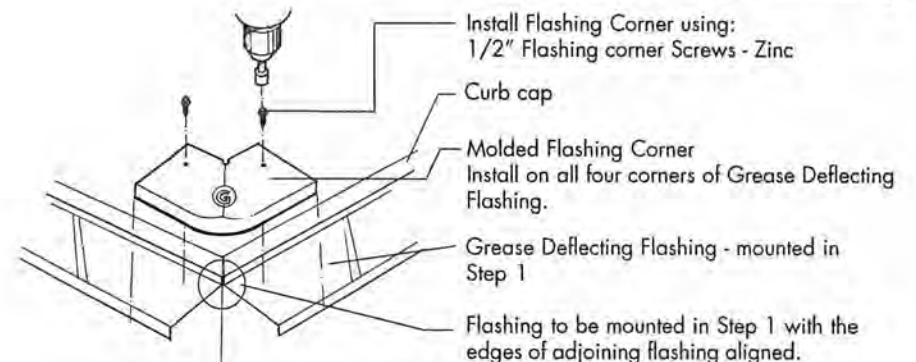

- Cut Molded Flashing Corner to fit around obstructions such as fan hinge kits.